



### Product description

Combi 2 is a multifunctional fitness machine that combines Arm Cycle & Chest Press for Upper Body Strength Training and Leg Press & Recumbent Cycle for Lower Body Strength Training in one compact unit. This versatile equipment allows users to strengthen and tone both upper and lower body muscles effectively. With features like adjustable weights, ergonomic back-rests, and hand-grips, it ensures safety, comfort, and ease of use, especially for the elderly or individuals with limited mobility. Combi 2 promotes overall strength, flexibility, and cardiovascular health, making it an ideal solution for a complete and balanced workout experience.

### Product information

Category	: SilverActive Elderly Fitness
Age group	: 16yrs & above
Product Code	: EF1001
Maximum users	: 5 user
Sizes (mm)	: L2250 x H1870 x W5145 mm

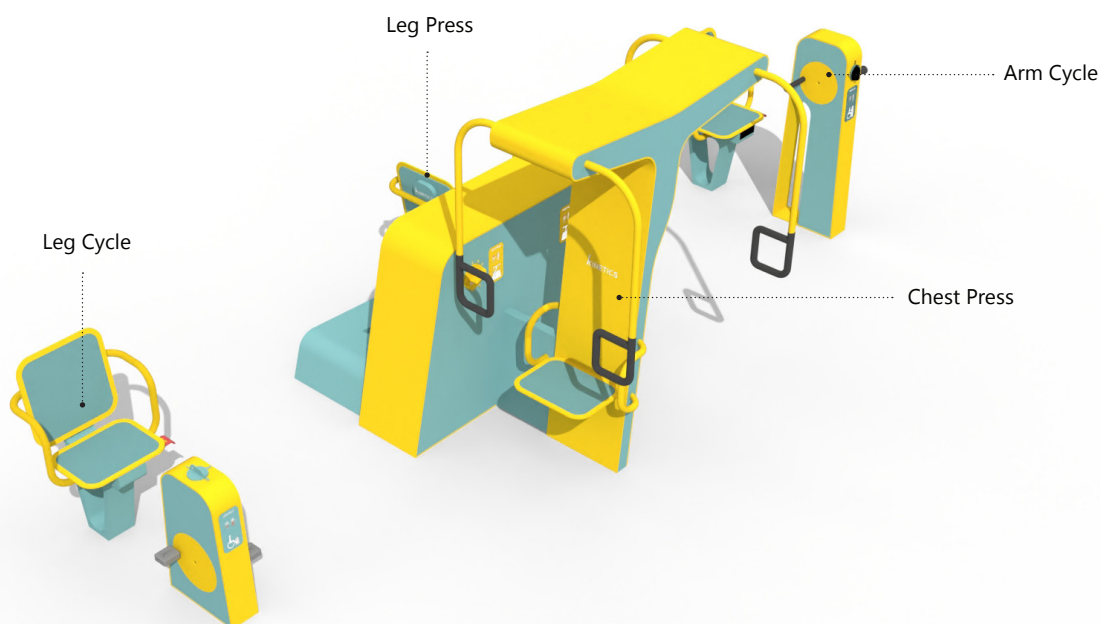

### KINETICS PLAY SDN. BHD. (1223254-U)

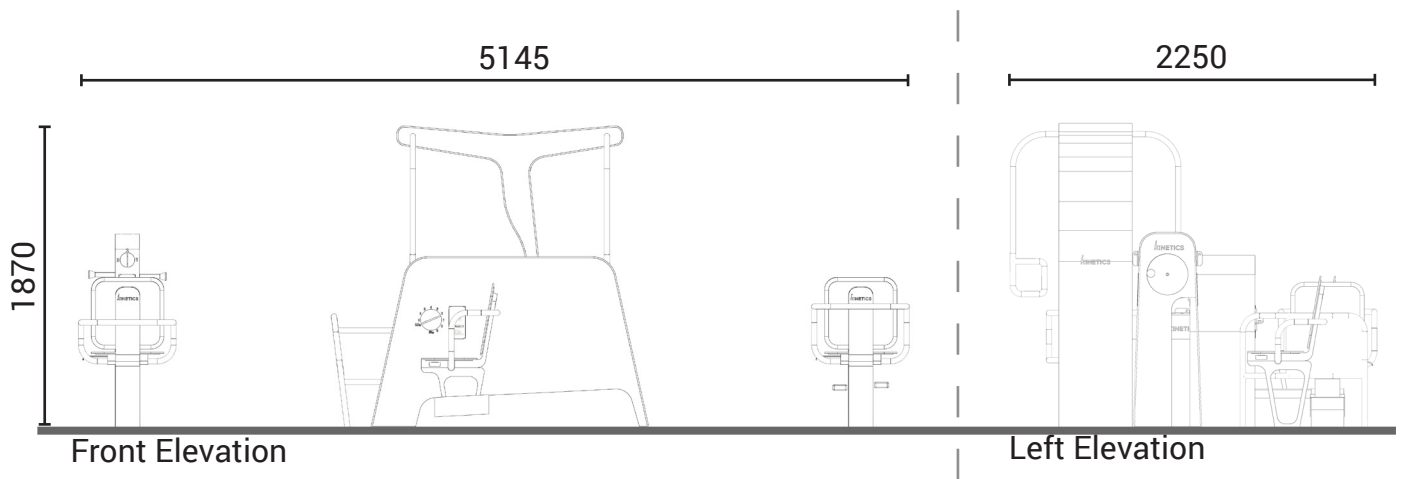
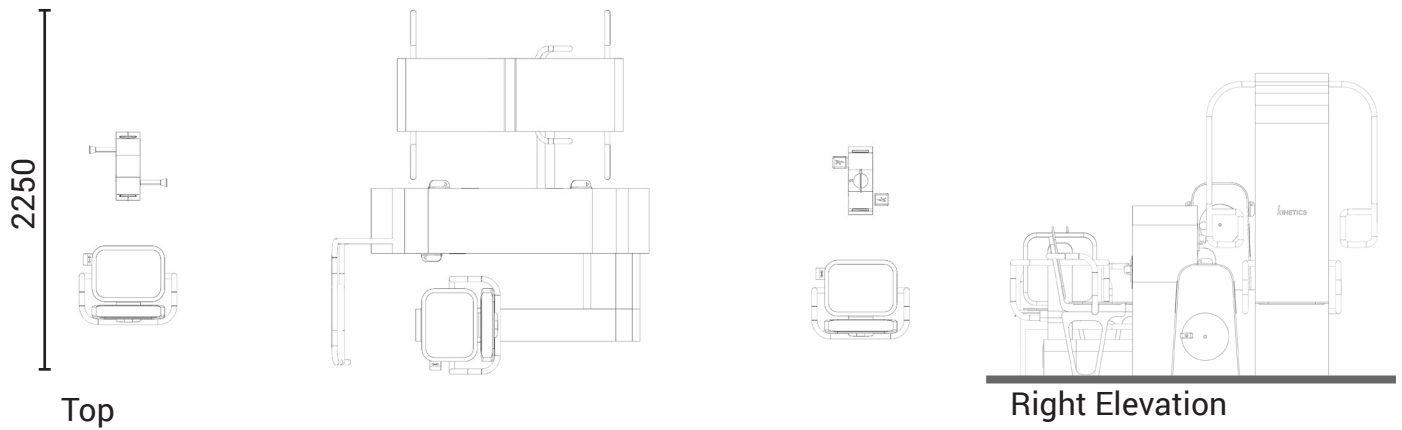

Subject to change without prior notice.

**KINETICS PLAY SDN. BHD. (1223254-U)**

Lot 2-44 Jalan SU7, Lion Industrial Park, Persiaran Tengku Ampuan, 40300 Shah Alam, Selangor, Malaysia.  
Tel: +603-5888 9104      Email: info@kineticsplay.com      Web: www.kineticsplay.com